

Microcontroller Based Heart Rate Monitor using Fingertip Sensors

¹Bhat A. P., ²Dhoble S. J., ³Rewatkar K.G.

¹Department of Electronics, RTM Nagpur University, Nagpur India-33

²Department of Physics, RTM Nagpur University, Nagpur India-33

³Department of Physics Dr. Ambedkar college, Nagpur India-10

Anup_b5@yahoo.com

Abstract: This paper presents the design and development of a microcontroller based heart rate monitor using fingertip sensor. The device uses the optical technology to detect the flow of blood through the finger and offers the advantage of portability over tape-based recording systems. The important feature of this research is the use of Discrete Fourier Transforms to analyse the ECG signal in order to measure the heart rate. Evaluation of the device on real signals shows accuracy in heart rate estimation, even under intense physical activity. The performance of HRM device was compared with ECG signal represented on an oscilloscope and manual pulse measurement of heartbeat, giving excellent results. Our proposed Heart Rate Measuring (HRM) device is economical and user friendly.

Keywords: Heart rate monitor; Fingertip sensor; Microcontrollers; Fourier transform

1. INTRODUCTION

Heart rate is the number of heartbeats per unit of time, typically expressed as beats per minute (bpm). Heart rate can vary, as the bodies need to absorb oxygen and excrete carbon dioxide changes during exercise or sleep. Medical professionals to assist in the diagnosis and tracking of medical conditions use the measurement of heart rate. Individuals, such as athletes, who are interested in monitoring their heart rate to acquire maximum efficiency, also use it. The wave interval is the inverse of the heart rate θ .

Changes in lifestyle and unhealthy eating habits have resulted in a dramatic increase in incidents of heart and vascular diseases. Furthermore, heart problems are being increasingly diagnosed on younger patients. Worldwide, Coronary heart disease is now the leading cause of death θ . Thus, the medical community welcomes any improvements in the diagnosis and treatment tools. In a clinical environment, heart rate is measured under controlled conditions like blood measurement, heart beat measurement, and Electrocardiogram (ECG) θ . However, there is a great need that patients are able to measure the heart rate in the home environment as well θ . A heart rate monitor (HRM) is a simple device

that takes a sample of the heartbeat signal and computes the bpm so that the information can easily be used to track heart conditions. The HRM devices employ electrical and optical methods as means of detecting and acquiring heart signals.

¹Corresponding author: "+91-99890904625,"
E-Mail: anup_b5@yahoo.com

Heartbeat rate is one of the very important parameters of the cardiovascular system. The heart rate of a healthy adult at rest is around 72 bpm. Athletes normally have lower heart rates than less active people. Babies have a much higher heart rate at around 120 bpm, while older children have heart rates at around 90 bpm. The heart rate rises gradually during exercises and returns slowly to the rest value after exercise. The rate at which the pulse returns to normal is an indication of the fitness of the person. Lower than normal heart rates is usually an indication of a condition known as bradycardia, while higher than normal heart rates are known as tachycardia.

Most HRM devices use a design where the signal is acquired from the subject and a filtering function is applied to remove the high order harmonics and noise

from the signal. This is then followed by a hardware or software that uses a zero crossing algorithms to count the number of beats during a given time interval. The zero-crossing algorithm may lead to false readings caused by local noise that may result in multiple locals zero crossings.

In this paper, we eliminated the zero-crossing problems by the use of Fourier Transform of the digitised signal. This is a reliable technique that guarantees the automatic filtering of any transient noise in the signal. The design and development of a low powered HRM device is presented. The device provides an accurate reading of the heart rate using optical technology. We incorporated the optical technology using standard infrared Light Emitting Diode (LED) and photo-sensor to measure the heart rate using the index finger. A microcontroller is programmed to acquire the signal using its embedded analogue to digital converter, ADC, and use the readings to compute the heart rate; eventually, the reading is digitally displayed on a LCD. In case the HRM device is used in a continuous monitoring mode 0, the device alert the medical professional or the person accompanying of the patient, if the heart rate falls outside a given range. A local audible alarm is also provided. The rest of the paper provides a discussion on the system overview; describes the full description of the HRM device and lists the experimental results.

2. SYSTEM HARDWARE

The proposed HRM device is intended to have the following features:

- The system provides an optical mechanism to detect physical changes.
- The system supports a keypad to allow the user to enter information like name, age and telephone number.
- The device is connected to an SMS modem to allow the transmission of an alert text message to a medical profession
- The system provides a LCD screen to

output the measured heartbeat rate.

- The device would provide an audible warning tone.

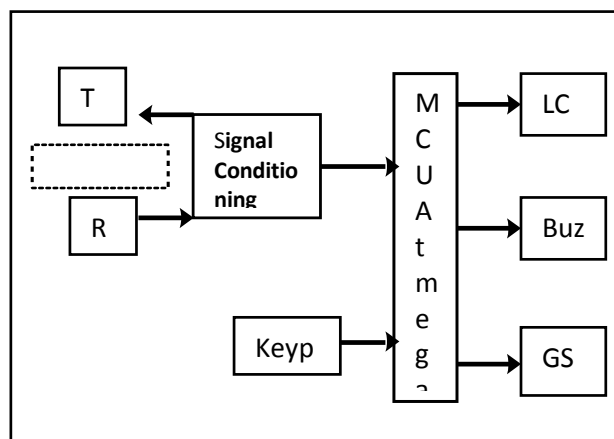

Figure 1. Shows the overview diagram of the proposed device.

The system consists of an infra red (IR) LED as transmitter and an IR phototransistor as a receiver that acts as a fingertip sensor

2.1 Fingertip Sensor

The sensor consists of an IR light emitting diode transmitter and an IR photo detector acting as the receiver. The IR light passes through the tissues. Variations in the volume of blood within the finger modulate the amount of light incident on the IR detector. Two practical configurations could be implemented to achieve this function. In the first configuration, the finger can be placed between the transmitter and the receiver as shown in Fig. 2. In the second design, both the IR transmitter and receiver could be placed on the same plane and the finger would function as a reflector of the incident light instead. The IR receiver monitors the reflected signal in this case. The IR filter of the phototransistor reduces interference from the mains 50Hz noise.

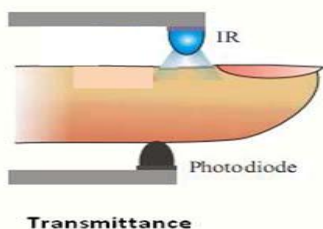

Figure 2. Fingertip sensor

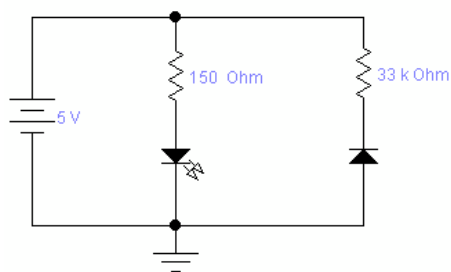

Figure 3. Shows our pulse detection circuit.

The IR LED is forward biased through a resistor to create a current flow. The values of resistors are chosen so that they produce the maximum amount of light output. The photo-resistor is placed in series with the resistor to reduce the current drawn by the detection system and to prevent short-circuiting the power supply when the photo resistor detects no light.

2.2 Amplification and Filter Stage

The filter/amplifier circuit is a standard design and is documented in many sources (e.g. [1]). The signal from the IR sensor is very weak where the voltage is just around $50\mu\text{V}$, containing a significant noise level. The signal is affected by interference caused resulted from movement of artefacts like rings and mains 50Hz. It is known that the standard ECG where the limits of integration are determined from our knowledge of the signal and the time of observation. ECG signal has frequency components in the range 0.05-200Hz. If filtered to the range 0-50Hz, the signal does not suffer any significant

loss of quality or information within the signal. The filtering process is necessary to block the higher frequency noise components present in the signal. A capacitor of $1\mu\text{F}$ value at the input of each stage is required to block the dc component in the signal

2.3 Physical Properties

The device operates using a 9V-battery source, which should last for one year under normal use. The package is small, lightweight and portable. The cost of the HRM device is kept to the minimum in order to maintain a competitive edge with products currently available in the market. The current estimate of the cost of the components is ~SDG150.

The microcontroller is the main component in our device. It acquires the ECG signal via the ADC, computes the heart rate, and controls the LCD, keypad and GSM modem. The microcontroller used in this study is the ATMEGA32. The driving software component includes the calculation algorithm to measure the heart rate. The overall flow of the software application is depicted in Fig. 4.

3. SYSTEM SOFTWARE

3.1 Discrete Fourier Transform

Determination of heartbeat bps depends on computing the Fourier Transform of the heartbeat signal. Assuming a relatively high heart rate of 120 bpm, we can compute the minimum sampling rate using the Nyquist-Shannon sampling.

Let us assume that a total N samples were collected during a time duration of T . If the time between samples is Δt , then the signal could be expressed as a piece wise step level, sample and hold, as:

$$g(t) = g(t_i) \text{ where } i\Delta t \leq t < (i+1)\Delta t \text{---(1)}$$

The Fourier Transform could be computed using the discrete data acquired by the ADC as follows:

$$G(f) = \sum g(t_i) e^{-j2\pi f t_i} \text{-----(2)}$$

The real and imaginary components are thus given

as

$$\text{Re}(G(f)) = \sum g(t_i) \cos(2\pi f t_i) \quad \text{-----} \quad (3)$$

$$\text{Im}(G(f)) = - \sum g(t_i) \sin(2\pi f t_i) \text{-----} (4)$$

A flowchart of the software system implementation

3.2 Heart Rate Range

Our device computes the bps and compares the measurement against the maximum safe limit for the subject in question. The maximum safe bpm value is computed depending on the gender of the subject and his/her age. A number of methods for the maximum safe bpm are used in the medical profession, including Martha, Londeree-Moeschberger, Miller and other techniques 0. For our study, we adopted the formulae used by UK practitioners to compute the upper limits, HR_{Max} as:

$$HRm = 216 - 1.09 \times \text{Age of female}$$

$$HRm = 202 - 1.09 \times \text{Age of Male}$$

The algorithm below summarises the software:

```

Initialise input and output Ports
Enter user data
Forever Do
    Acquire samples from ADC (5 Seconds)
    Compute Fourier components
    Find Heartbeat rate
    Display rate on LCD
    If HR is outside the safe range
        Send SMS msg to assigned person
        (if not already sent)
    Switch Buzzer ON Else
    Switch Buzzer OFF (if already ON)
Endif
Endforever
    
```

4. RESULTS AND DISCUSSION

Fig. 4 shows the analogue signal acquired by the sensors and input to ADC port of the microcontroller. The signal is consistent with the

standard ECG signals used to measure the heartbeat rate and is also used in other types of clinical diagnosis. In Fig. 5 we show the frequency analysis of a typical heartbeat signal. The Fourier Transform of the 5sec interval shows a dominant peak power spectral density obtained from the Fourier Transform at 72 bps. The second largest peak, i.e. the second harmonic of the heartbeat rate, is located at 144bps. Note that the algorithm implemented in this study searches only for the rate with the highest spectral density.



Figure 4. Analogue signal

The final device was used to measure the heartbeat rate of a number of male and female volunteers. The results as well as the bps measured simultaneously using the heartbeat pattern of the same volunteers as displayed on the oscilloscope are shown in Table. 1. These results show excellent agreement

Figure 5. Fourier analysis and curve fitting

Age	Condition	HR (bps)	HR Normal (bps)
24years	Before exercise	65	64
	After exercise	90	88
15 years	Before exercise	91	88
	After exercise	110	100

Table 1. Heart beat rate measurement using the developed device and via an oscilloscope

Gender	Age	HR on LCD	HR on scope	Error %
Male	22	97	96	1.03
Male	22	83	81	2.41
Male	20	78	78	0
Male	22	90	87	3.33
Male	20	80	79	1.25
Female	22	77	77	0
Female	22	104	103	0.96
Female	19	75	75	0
Female	20	69	71	2.81
Female	22	83	85	2.35

Table 2. Measurements of heartbeat rate before and after exercise

REFERENCES

[1]Leslie Cromwell, " Biomedical instrumentation and mesurment" 2nd edition Printice Hall of India Pvt. Ltd. New Delhi 2004,p.150-160.
 [2] R.S. Khandpur, "Handbook of Biomedical Instrumentation", Tata McGraw Hill publishing Company, New Delhi 1998, p12-125.
 [3] W. J. Tompkins, "Biomedical digital signal processing", Printice Hall of India Pvt. Ltd. New Delhi 2004,p41
 [4] M.Rayner, Coronary heart disease statistics,, British Health Promotion Research Group, Heart

5. CONCLUSIONS

The design and development of a low cost HRM device has been presented. The device is ergonomic, portable, durable, and cost effective. Tests have shown excellent agreement with actual heartbeat rates. This device could be used in clinical and nonclinical environments. Individual users, e.g. athletes, can also easily use it during sporting activities. The device could also be used as a monitoring instrument exploiting the SMS capabilities provided by this system.

This study used the standard Fourier Transform to compute the spectral density. The overall efficiency of the device could be improved by the use of Fast Fourier Transforms.

The device could be further developed into a continuously Monitoring device that could be used to detect the heart beat anomalies associated with certain heart conditions. This would be made possible by analyzing the heartbeat signal in the frequency domain.

Foundation Department of public health, University of Oxford, 2007.

[5] Mohamed Fezari, Mounir Bousbia-Salah, and Mouldi Bedda, "Microcontroller Based Heart Rate Monitor",The International Arab Journal of Information Technology, Vol. 5, No. 4, 2008.

[6]Dogan Ibrahim, Kadri Buruncuk,"Hear Rate Measurement from the Finger using a low cost microcontro ller"

http://www.emo.org.tr/ekler/a568a2a_a8c19a31_ek.pdf

[5] Boashash, B., "Time-Frequency Signal Analysis

and Processing: A Comprehensive Reference”,
Oxford: Elsevier Science, 2003.

[7] R. Fensli, "A Wireless ECG System for
Continuous Event Recording and Communication to
a Clinical Alarm Station", Proc of the 26th Annual
International Conference of the IEEE EMBS, 2004.

[8] <http://www.brianmac.co.uk/maxhr.htm>, Accessed
on 02/09/2011

[9] Kohler, B.-U.; Hennig, C.; Orglmeister, R. The
principles of software QRS detection. Engineering in
Medicine and Biology Magazine IEEE, vol. 21, , 2002
pp. 42 – 57.

[10] Piotrowskia Z.; Rózanowski K. Robust Algorithm
for Heart Rate (HR) Detection and Heart Rate
Variability (HRV) Estimation. ACTA PHYSICA
POLONICA, vol. 118, No. 2010, pp. 131 – 135,